

Nýťovací matice s plochou hlavou LF-CO

OCEL Zinek Bílý

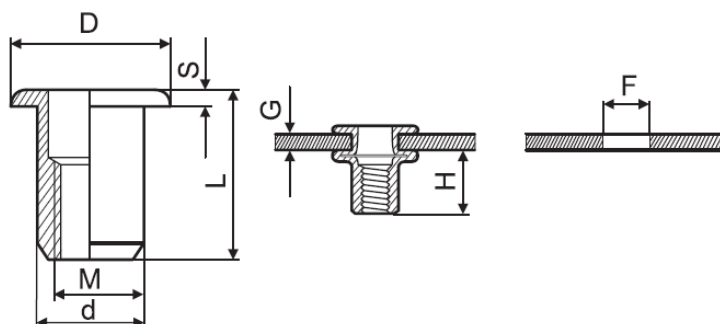

DIN:
ČSN:
ISO:



M	Svěrná tloušťka	F +0,1	L	D	d	S	H	kód Fastek
M3	0,5-1,5	5,0	8,5	7,2	4,9	0,8	4,7	9MLFCO3009S
M3	1,5-2,5	5,0	9,5	7,2	4,9	0,8	4,7	9MLFCO3010S
M4	0,5-2,0	6,0	10,5	8,5	5,9	0,8	6,0	9MLFCO4010S
M4	2,0-3,5	6,0	12,0	8,5	5,9	0,8	6,0	9MLFCO4012S
M5	0,5-2,5	7,0	13,0	10,0	6,9	1,0	7,5	9MLFCO5013S
M5	2,5-5,0	7,0	17,0	10,0	6,9	1,0	8,5	9MLFCO5017S
M6	0,5-3,0	9,0	15,5	12,3	8,9	1,3	9,2	9MLFCO6015S
M6	3,0-5,5	9,0	18,0	12,3	8,9	1,3	9,2	9MLFCO6018S
M8	0,5-3,5	11,0	18,5	15,0	10,9	1,5	11,5	9MLFCO8018S
M8	3,5-6,0	11,0	21,0	15,0	10,9	1,5	11,5	9MLFCO8021S
M10	0,5-2,5	13,0	17,0	16,3	12,9	1,6	11,5	9MLFCOX017S
M10	2,5-4,0	13,0	21,0	17,0	12,9	1,6	12,5	9MLFCOX021S
M12	1,0-4,0	15,0	22,0	18,0	14,9	1,7	13,5	9MLFCOX222S
M12	4,0-6,5	15,0	25,0	18,0	14,9	1,7	13,5	9MLFCOX225S